

PLATEN, 2.00" FRONT

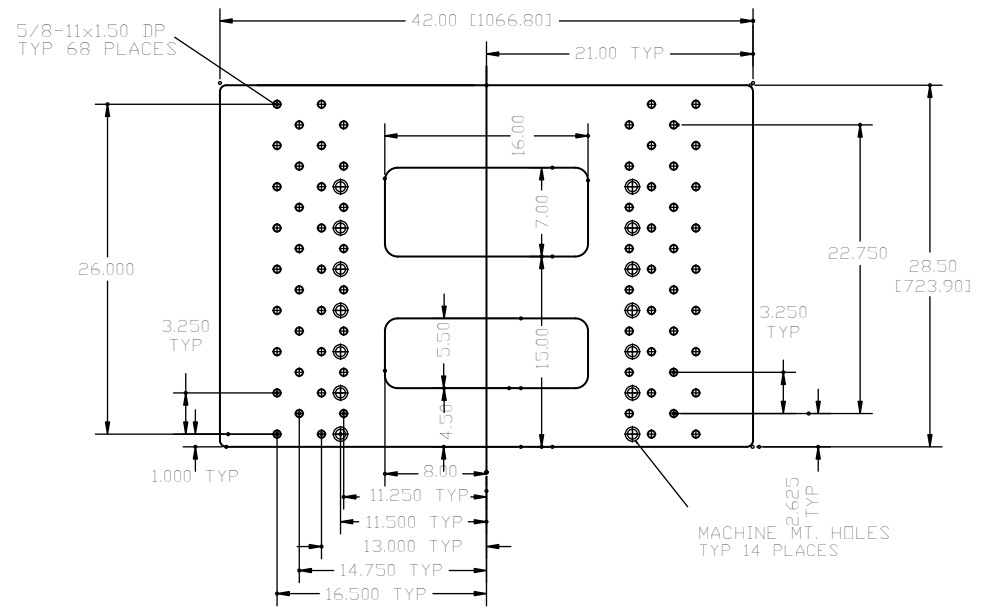

PLATEN, 2.00" MOVABLE

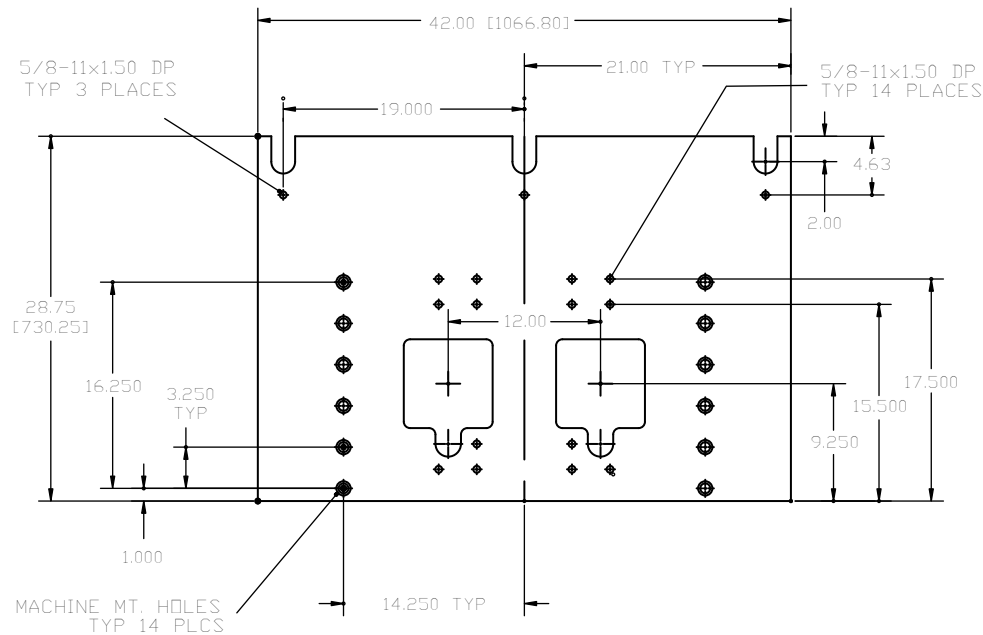

PLATEN, 2.00" REAR

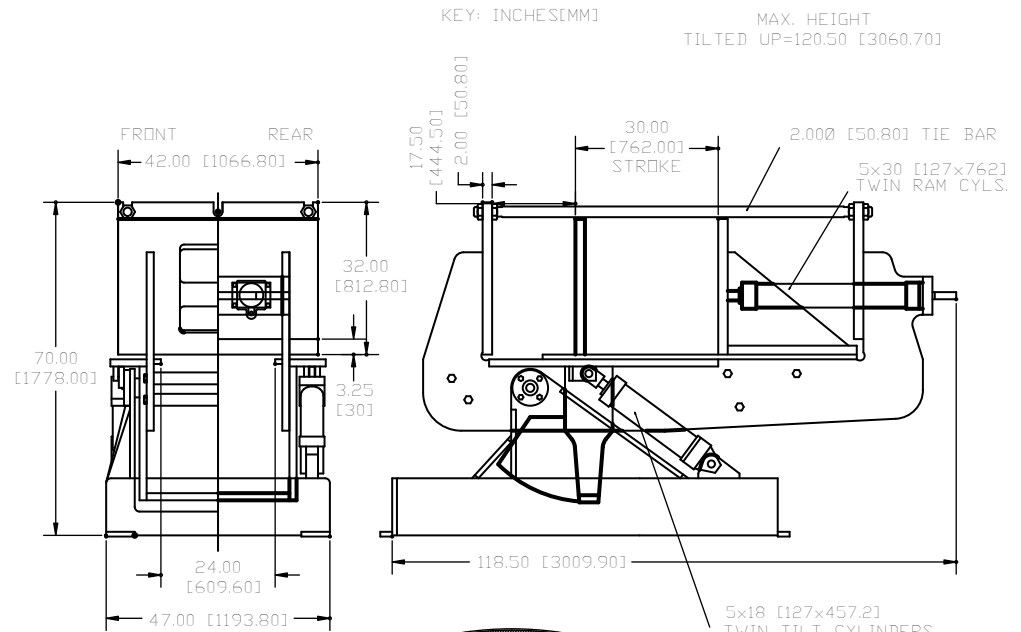

KEY: INCHES[MM] MAX. HEIGHT TILTED UP=120.50 [3060.70]

**HALL**  
PERMANENT MOLD MACHINES